

MICROWAVE SUPERCOMPONENTS

MULTI-FUNCTION ASSEMBLIES (MIC's) 0.5-18 GHz

elisra *electronic
systems ltd.*
Microwave Division

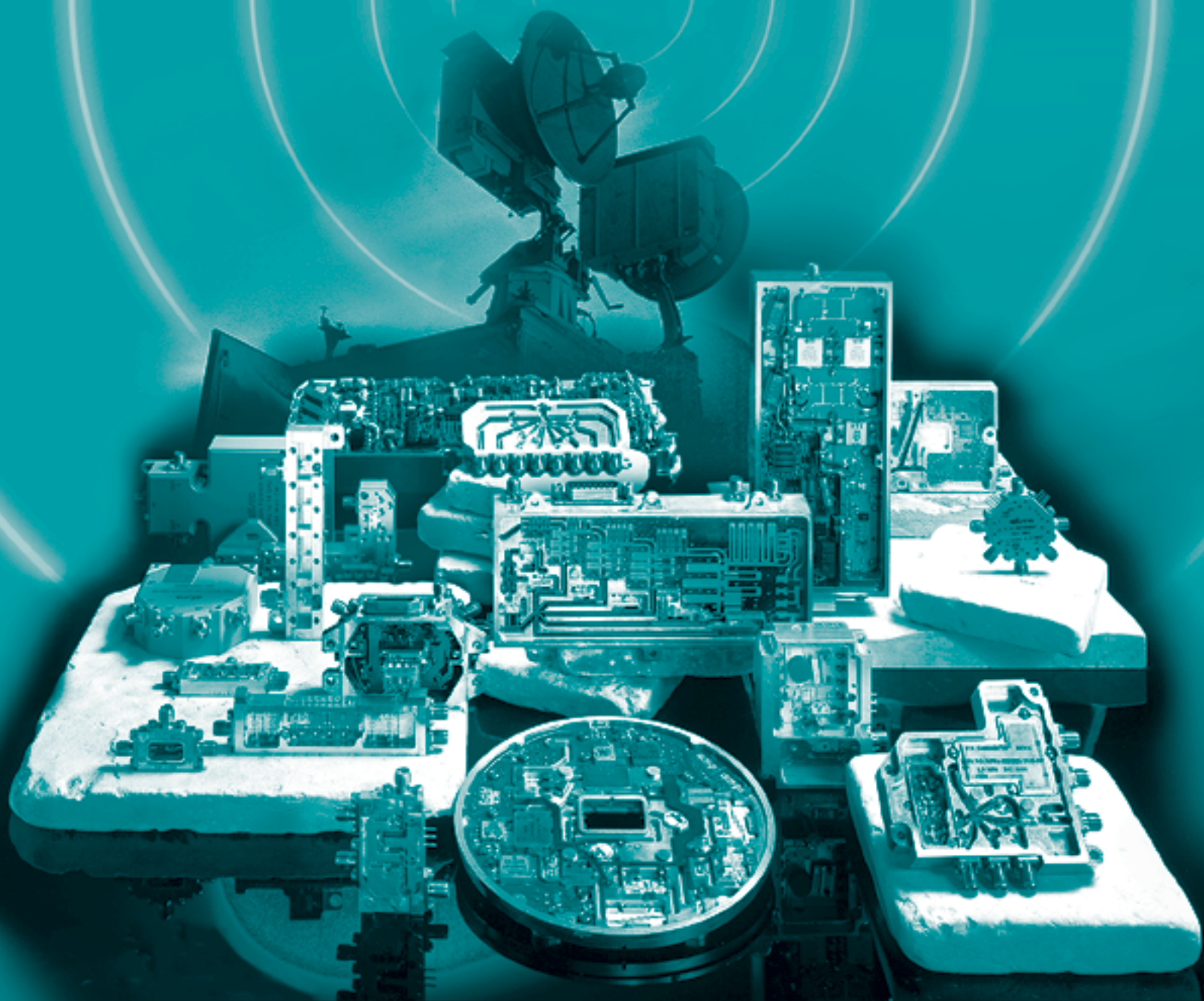

Warranty Elisra warrants products of its manufacture to be free from defects in material and workmanship under conditions of normal use. If within one year after delivery to the original owner and after prepaid return by the original owner, any product is found to be defective, Elisra shall, at its option, repair or replace said defective unit. This warranty does not apply to products which have been disassembled, modified or subjected to conditions exceeding the applicable specifications or ratings. In addition, this warranty does not apply to tubes, transistors, diodes, and fuses. Elisra reserves the right to make design changes without notice on any of its products without any obligation to make the same or similar changes to units previously purchased. In no event does Elisra assume liability for installation, labor or for consequential damages. This warranty is the extent of the obligation or liability assumed by Elisra with respect to its products, and no other warranty or guarantee is either expressed or implied.

Elisra, the Elisra logo are trademarks of Elisra Electronic Systems Ltd. Other company and brand, product and service names are trademarks or registered trademarks of their respective holders. Specifications are subject to change without notice.

Microwave Supercomponents Multi-Function Assemblies (MIC's) 0.5-18 GHz

T A B L E O F C O N T E N T S

PREFACE

Meet Elisra	4
-------------	---

SUPERCOMPONENTS (MIC's)

General Information	8
---------------------	---

SAMPLES WITH SPECIFICATIONS AND DIAGRAMS

RF Receiver	10
Up/Down Converter	13
Switched Filter	14
Super Heterodyne Receiver (S.H.R.)	16
Extended Range DLVA Assy	17
AGC Unit	21
VCO Assy	20
Dual Channel Front End Receiver	24
Dual Output Front End Receiver	25
Dual Band LO Distributor	26

ORDERING ADDRESS

48 Mivtza Kadesh Street
Bene-Beraq 51203, Israel
Tel: 972-3-617 5655 Fax: 972-3-617 5299
www.mw-elisra.com Email: trm1@elisra.com

Meet Elisra

Your Source for Quality RF and Microwave Components and Subsystems



Elisra Electronic Systems is a recognized leader in sophisticated electronic systems and components for defense and civilian markets.

Elisra Microwave Division has over 30 years of proven experience in supplying best-of-class components and subassemblies for a wide variety of

RF and Microwave applications covering the frequency range of 1 MHz to 50 GHz. Modern production facilities operating under a stringent framework of quality assurance standards have established Elisra as a worldclass and preferred supplier of products with unsurpassed reliability.



Our company's highly skilled teams of engineers and technicians, renowned for their technological expertise, have been the cornerstone of our leadership status in both military and commercial markets.

Elisra Defense and Commercial Applications All Across the Globe

Defense applications are known for their demanding and stringent requirements and Elisra systems have been proven with thousands of hours in the field. Based on our wealth of military expertise, combat know-how and adaptability, we also provide creative and competitive solutions for commercial applications. With more than a \$46 million turnover, our advanced technologies have been brought to all corners of the world. Our growing client list includes such notable companies as Motorola, Lockheed Martin, BAE Systems, EADS, IBM, British Telecom, Deutsche Telekom, and many others.

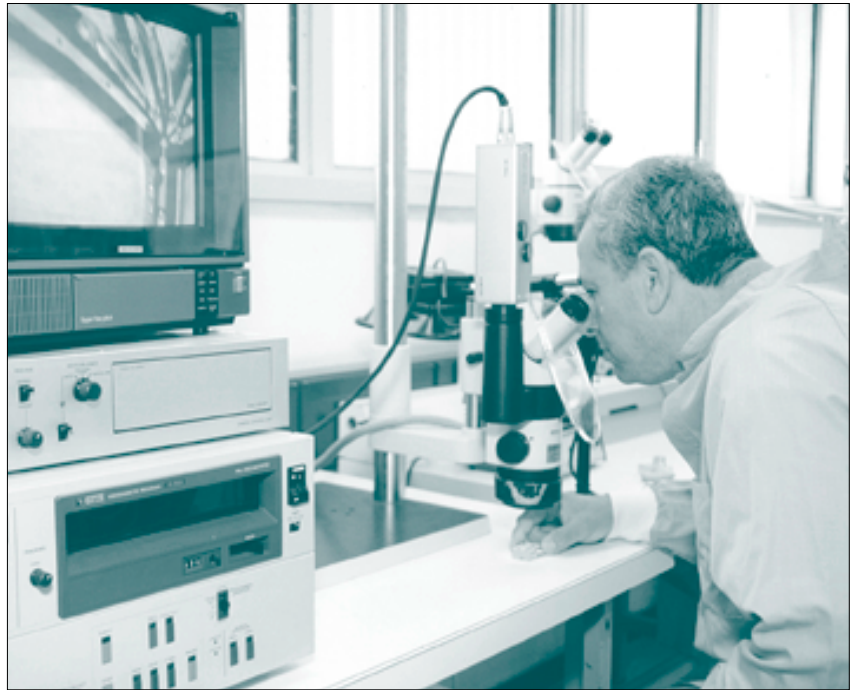

Modern Facilities and Experienced Staff

Our modern plant occupies more than 22,000 square meters of floor space and is located in suburb of Tel-Aviv, within close proximity to Ben Gurion International Airport. Over the years, we have built up a team of experienced and committed staff employing a highly skilled group of more than 260 microwave engineers, technicians, production workers and marketing specialists. They support all projects from their inception through to completion with ongoing after-sales support. Our production site also comprises state-of-the-art equipment and facilities including "cleanrooms", laser processing machines, and automatic "pick-and-place" equipment. The majority of the company's engineers and technicians are reserve officers and soldiers in the Israeli Defense Forces, adding unmatched knowledge of the battlefield experience. It is this



very blend of technological expertise and in-depth understanding from real-life scenarios that is the foundation of our position of distinction in the Industry.

Comprehensive Quality Assurance and Reliability Program

Elisra is synonymous with reliability and quality by virtue of the fact that our products are deployed in some of the most innovative and sophisticated military and commercial systems. This is achieved by careful in-house planning and design, accurate workmanship standards, controlled procedures and rigorous inspections. All phases of our activities from design through to production are carefully monitored by the independently managed quality assurance department personnel. Elisra's facilities and products are ISO-9001 certified, reflecting internationally recognized standards. Elisra's quality assurance program is based on the following military specifications and standards: MIL-E-4158, MIL-E-5400, MIL-E-16400, MIL-M-38510, MIL-STD-202, MIL-STD-454.

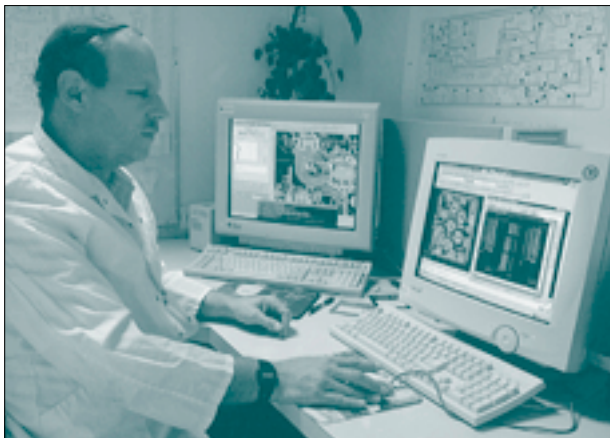

In-house capabilities at all levels of project design, development, production, testing and system integration assure outstanding accuracy and quick time-to-market.

All systems and components are inspected to conform to precise requirements and specifications.

Comprehensive testing includes simulation of some of the most extreme conditions possible via the use of special vibration, temperature and humidity chambers.

On-Going Customer Support and Satisfaction

The proven reliability of our products is a reflection of the continuous communication we have with our customers.

To ensure that our customers' requirements are met, constant dialogue and feedback are attained at every stage of the development process. Once systems are installed, we provide on-going documentation, training and support to ensure that our clients become expert and successful users of the technology.

Wide Product Portfolio

In this catalog you shall find a brief overview of microwave supercomponents offered by Elisra Microwave Division.

For more details about our other microwave products, please visit our web site:

www.mw-elisra.com

Supercomponents



[Index](#)



Supercomponents

A Complete Miniaturized Subsystem Consisting of Quality Microwave Components Density Packaged into One Enclosure

- ▶ High Performance
- ▶ Customer Designed
- ▶ Miniature Compact Package
- ▶ Enhanced Electrical Performance

GENERAL INFORMATION

Supercomponents represent an answer to the ever-present challenge of integrating high microwave performance into small packages. As a recognized leader in the development and manufacture of supercomponents, Elisra has leveraged its knowledge-base of diverse technologies and microwave components into providing the best possible subassemblies on the market today.

Supercomponents: Fully Integrated Multi-Function Assemblies

These miniaturized subsystems consist of numerous microwave components which are assembled into a small package. The package includes such diverse components as amplifiers, switches, oscillators, filters and MMIC devices.

Every component is carefully designed and adapted to meet full performance custom-specifications, while taking into account the particularly compact supercomponent enclosure requirements.



Why Supercomponents?

When operating within complex EW, ELINT/COMINT, radar or communication systems, performance versus size/weight constraints are almost always an issue. Supercomponents provide an excellent, cost-effective solution to these challenges – especially when larger quantities are involved.

Since compact integration eliminates many connector interfaces, overall electrical performance is often enhanced. Our supercomponents frequency demonstrate improved VSWR and enhanced gain and phase characteristics.

These integrated subassemblies perform diverse functions for military and commercial applications all “in-a-box”, simplifying the traditional process of dealing with a varies mix of components, interfaces and vendors.



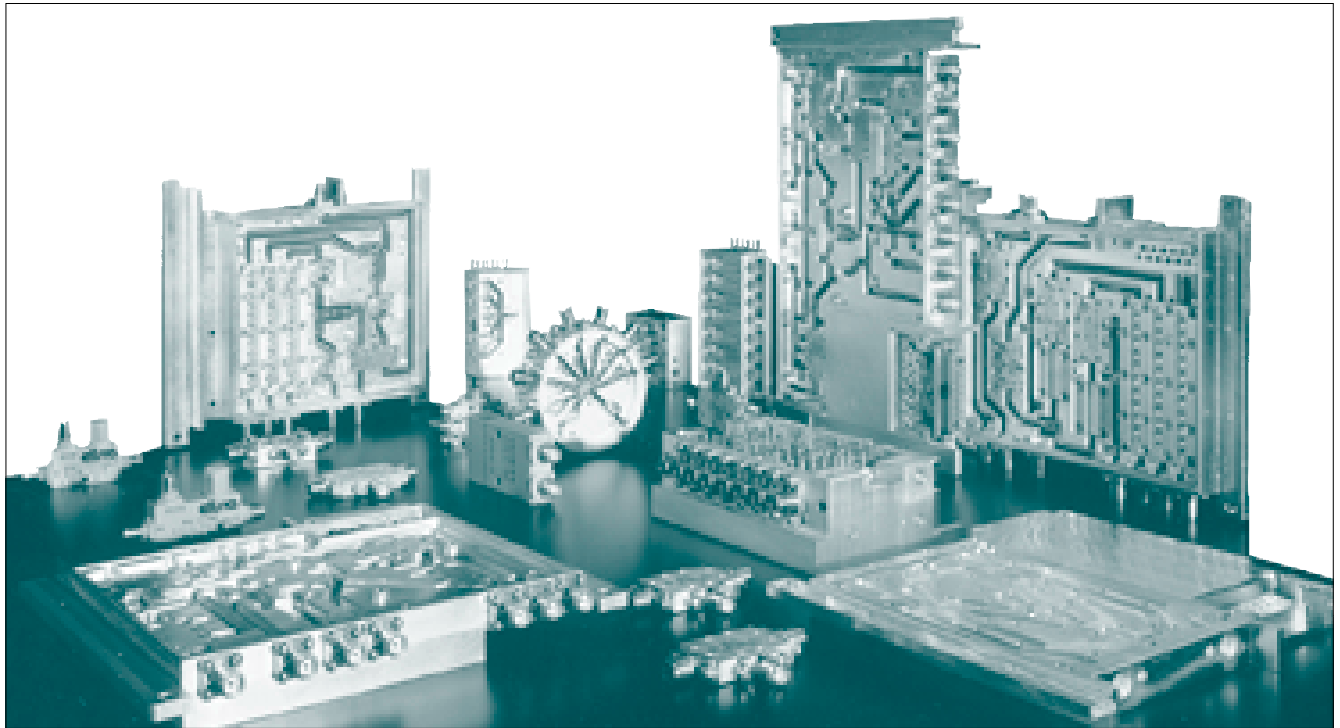

Why Elisra and Supercomponents?

The development and manufacture of supercomponents are a natural extension of our qualified technology and have positioned us as dominant players in the industry. More than 30 years of design and manufacturing experience have given us the opportunity to produce high quality, high performance components and sub-assemblies for a variety of applications.

Leading-edge MMIC components are integrated in our MIC supercomponents to achieve optimal performance at optimal prices.

- ▶ **MMIC Low Noise, Gain or Power Stages**
- ▶ **MMIC Switches**
- ▶ **MMIC Attenuators (DCA's)**
- ▶ **MMIC Mixers**
- ▶ **MMIC Broadband Phase-Shifters**
- ▶ **MMIC Regulator and Driver Circuitry**
- ▶ **Voltage Controlled Attenuators**

Elisra Supercomponents can Make the Difference in Your Systems

Our proven track record in this field is based on a complete infrastructure which supports in-house research, engineering, quality control and after-sales maintenance.

In the following pages you will find a broad range of examples of our Microwave Multi-Function Assemblies 0.5 - 18GHz.

Our qualified staff of experienced sales and design engineers are available to assist you in specifying the supercomponents needed to meet your special requirements.

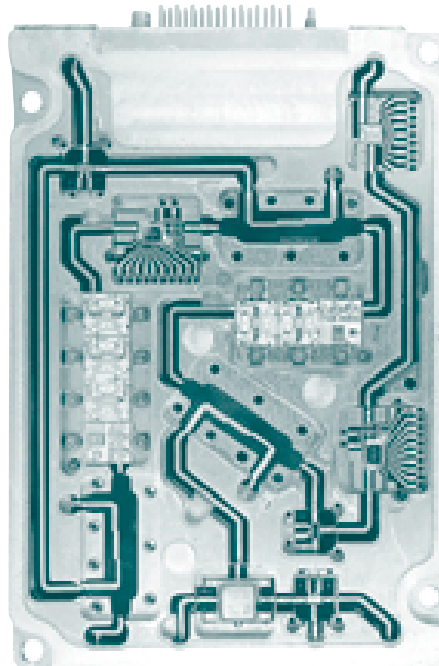

RF Receiver

FREQUENCY RANGE: 2-18 GHz

- ▶ RF to IF Output
- ▶ RF to Video Output
- ▶ High Dynamic Range RF to IF Converter

APPLICATION

- ▶ EW Systems

TECHNOLOGY

- ▶ Microstrip
- ▶ MMIC
- ▶ Suspended Quintuplexer
- ▶ PIN Diode Switches
- ▶ Hermetically Sealed (Laser)

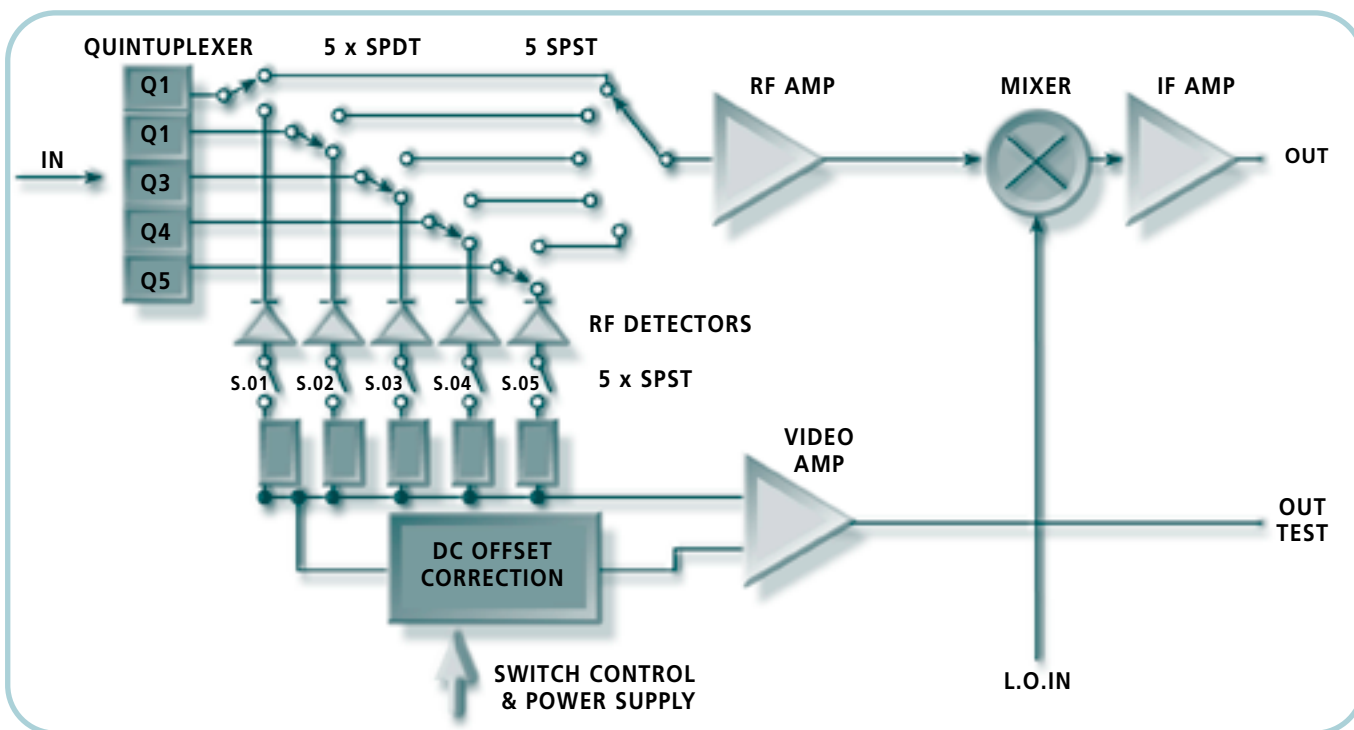
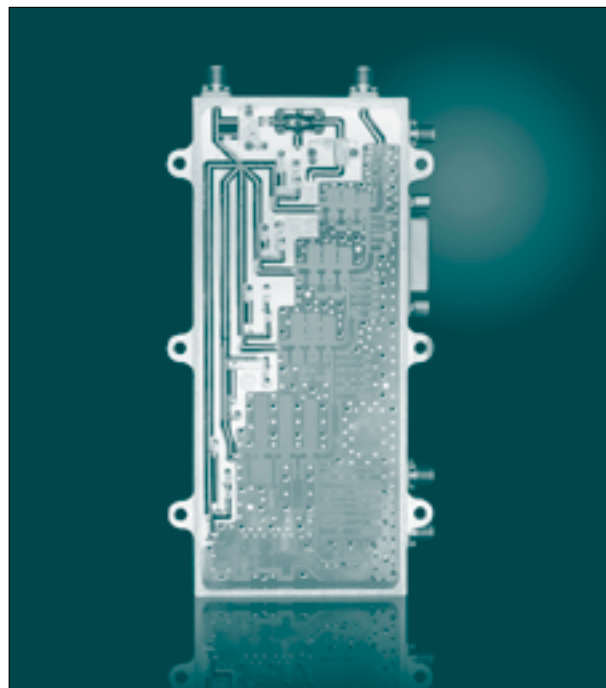

RF RECEIVER (continued)

GENERAL INFORMATION

The RF Receiver (RFREC) is an integrated unit consisting of the following components:

- Quintuplexer (Q)
- 5 x SPDT Switch
- Single Pole 5 Throw Switch (SP5T)
- Five Broadband RF Detectors (RFD)
- 5 Video Switches (5 x SPST)
- Video Amplifier (VA)
- RF Amplifier
- RF Mixer
- IF Amplifier (IFA)

The unit has two outputs:

- 1 of 5 selected RF bands
- Switchable RF detected signals

The incoming signal is fed to the Quintuplexer (Q).

The Quintuplexer consist of five sub band filters (Q1, Q2, Q3, Q4, Q5).

The output of the Quintuplexer is fed to SP5T non reflective switch.

The Output of the SP5T Switch is fed to an isolation amplifier and series attenuation to the RF mixer, the IF output is amplified by the IF amplifier.

The outputs of the quintuplexer, which are not selected by the SP5T, are fed to 5 RF Detectors (RFD) which are located instead of the termination resistors of the SP5T switch. After every detector there is an analog switch, and the output of the switches are summed to the Video Amplifier. The DC correction circuit is incorporated into the Video Amplifier. The control of the analog switch is activated through a decoder

ELECTRICAL SPECIFICATIONS

-15 VDC; I = 100 mA max.

+15 VDC; I = 300 mA max.

+5 VDC; I = 280 mA max.

-5.2 VDC; I = N.A.

CHARACTERISTICS

Input Frequency Range

2 – 18 GHz min.

The frequency range is divided to five sub bands Q1- Q5 (band edge cross-over frequency).

The accuracy of cross-over frequencies is $\pm 0.5\%$

Noise Figure

Frequency Range: 50 – 700 MHz including insertion loss in the passband of every sub band. (Passband the range of frequency in the sub band with insertion loss less than 1.5 dB). For sub bands Q3, Q4, Q5 the noise figure is calculated for the third harmonic of the mixer (20 dB conversion loss)

N.F. Max. dB

Band/F (Mhz)	50	300-600	700
Q1	20.5	19.5	20
Q2	20.5	19.5	20
Q3A	21	20	20.5
Q3B	31	30	30.5
Q4	31	30	30.5
Q5	32.5	31.5	32

F=Frequency in MHz

Gain As a Function of Input Frequency in Every Sub-Bands Q1, Q2, Q3, Q4, Q5

The IF frequency range 50 to 700 MHz.

Gain/Frequency Sub-Bands Q1 – Q5

Subband Filter	Passband Gain (dB)	
	Min.	Max.
Q1	+1	+5
Q2	+1	+5
Q3	-1	+3
Q4	-10	-5
Q5	-12	-6



RF RECEIVER (continued)

VSWR In/Out

Input to the RF Receiver

2 : 1 max 85% of the bandwidth
2 – 18 GHz

2.5 : 1 max 15% of the bandwidth
2 – 18 GHz

Local Oscillator Input

2.5 : 1 max

Output of the RF Receiver (OUT)

1.8 : 1 max

Recovery Time

The time that takes the unit to get out of any saturated state due to excess input power to full performance as described in the specification
100nsec max.

Incident Power Level

-65 dBm to +14 dBm

Power Input Compression Point

RF Band	1 dB Compression Point
Q1	+7 dBm min
Q2	+7 dBm min
Q3	+8 dBm min
Q4	+8 dBm min
Q5	+9 dBm min

Power Output at 1 dB GCP

(The measurement shall be done at the component level)

(dB) Compression Point	(dBm min) Power Output
+0.25	+11
+0.5	+12.5
+1	+14

Power Handling Capability

+24 dBm max

Switching Speed (of the SP5T Switch)

The time required for the unit to attain 90% of the final RF signal reference to the 50% level of the command signal
1µsec max

Third Order Intercept Point

For fundamental mode of the mixer

+18 dBm min

For third harmonic of the mixer

+8 dBm min

Second Order Intercept Point

For fundamental mode of the mixer

+21 dBm min

For third harmonic of the mixer

+11 dBm min

The RF and LO frequencies have to be chosen such that the intermodulation frequency will be between 50 – 600 MHz

Setting Time to 0.1%:

50 nsec max.

Pulse settling time is defined as the time for the pulse to rise from 10% RF and settle to within ± 0.5 dB of final value for pulse dynamic range of 35 dB

Output Impedance:

$51\Omega \pm 0.5\Omega$ max.

The load of the output test is 100Ω

Analog Switch Switching Time:

1 µsec max.

The time required for the switch to attain 99% of the final voltage at the test output. (From "OFF" to "ON" and from "ON" to "OFF")

ON to OFF Isolation Rejection Ratio at Frequency of 40 MHz:

50 dB min.

Cross Coupling Rejection Ratio at Frequency of 10 MHz:

80 dB typ

Is the leakage between each channel to the other channels

Isolation of the SPDT Switch:

45 dB min.

LO Power:

13 – 20 dBm

Switched Filter

FREQUENCY RANGE: 6-18 GHz

- ▶ 6 Channel Preselector
- ▶ High Speed Switching
- ▶ High Rejection Filters

APPLICATION

- ▶ EW Systems

TECHNOLOGY

- ▶ Microstrip
- ▶ MMIC Amplifier
- ▶ PIN Diode Switches
- ▶ Comb Filters
- ▶ Hermetically Sealed (Laser)

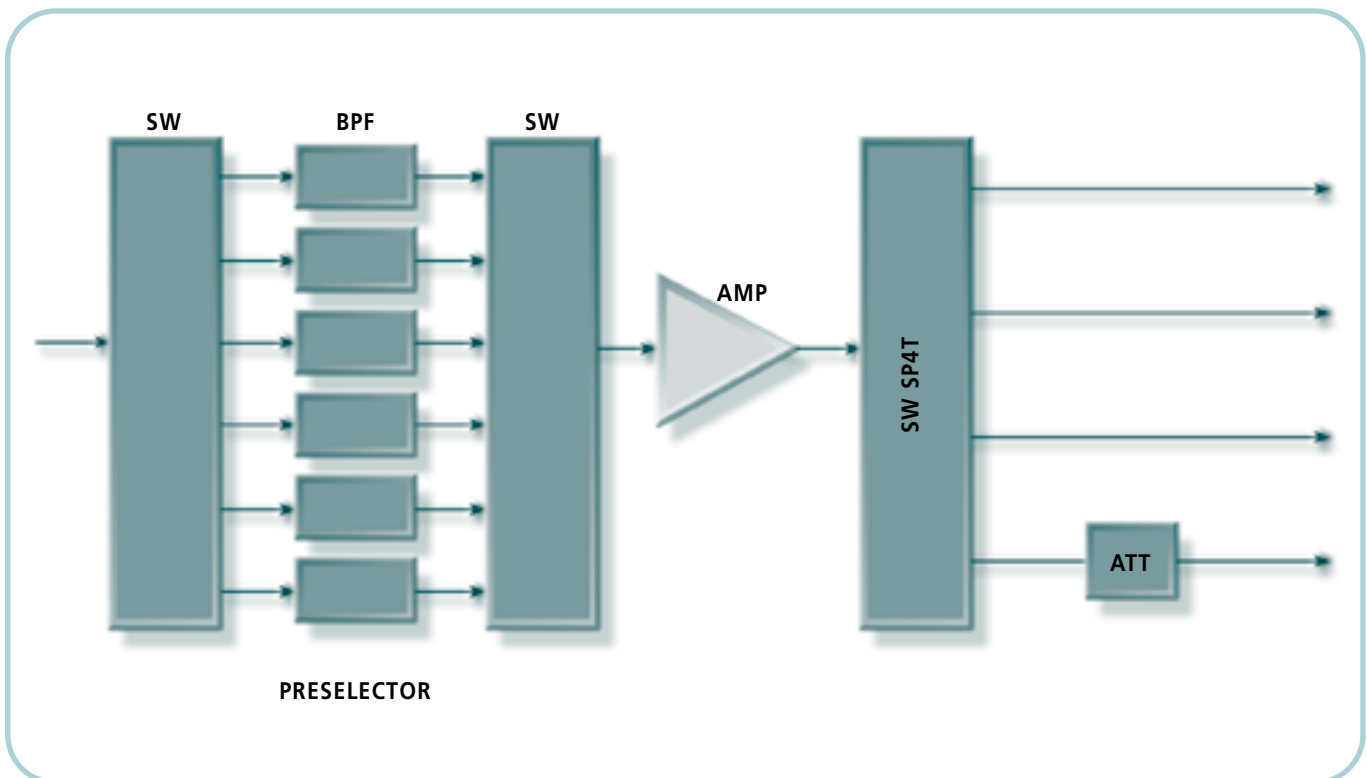
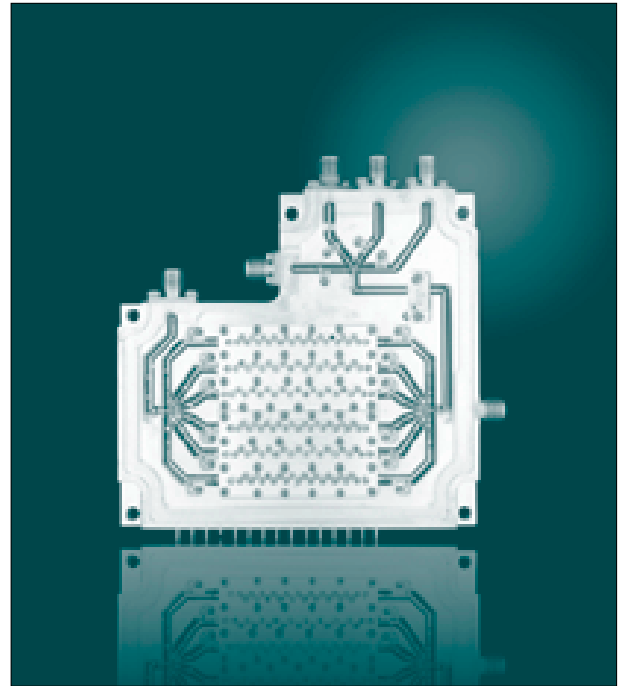

SWITCHED FILTER (continued)

ELECTRICAL SPECIFICATIONS

Features	Specifications
Frequency Range:	6-18 GHz
Out of Band Rejection:	
FL - 2 GHz to FL-1GHz	55 dBc min.
FH + 1 GHz to FH + 2GHz	55 dBc min.
2 GHz to FL - 2GHz	70 dBc min.
FH + 3 GHz to 19.5GHz	70 dBc min.
Gain:	3 –12 dB
Gain Variation Between Any Two Adjacent Bands:	1 dB, max.
Gain Flatness for Any 800 MHz Bandwidth:	1 dB, max.
VSWR In/Out:	2:1, max.
1 dB Compression Point (Output):	+13 dBm, min.
Noise Figure:	14 dB, max.
3rd Order Intercept Point (Output):	+20 dBm, min.
Switching Speed:	45 nsec, min.
Video Leakage:	
DC- 2 GHz@1 MHz Spectrum Res,	-20 dBm max.
2 - 18 GHz@ 100 kHz Spectrum Res,	-30 dBm max.
DC - 2 GHz	After 40 nsec, 0 mV
SP4T Isolation:	70 dB, min.
Power Consumption:	+12V, 160 mA +5V, 220 mA -12V, 170 mA

SHR Module

RF INPUT: 0.5-18 GHz

- ▶ Outputs: Linear & Log IF
- ▶ Triple Down Conversion
- ▶ Phase Matching (Pairs): $\pm 15^\circ$
- ▶ Spurious Free Dynamic Range: -45 dBc
- ▶ Low Power Consumption 5W

APPLICATION

- ▶ Airborne EW System

ENVIRONMENTAL

- ▶ Full Military Requirements
- ▶ Hermetically Sealed (Laser)

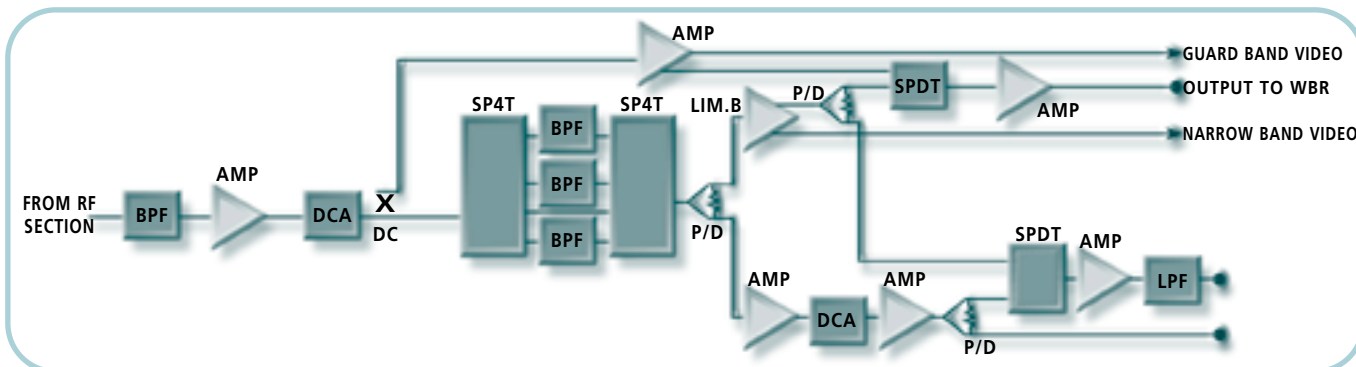
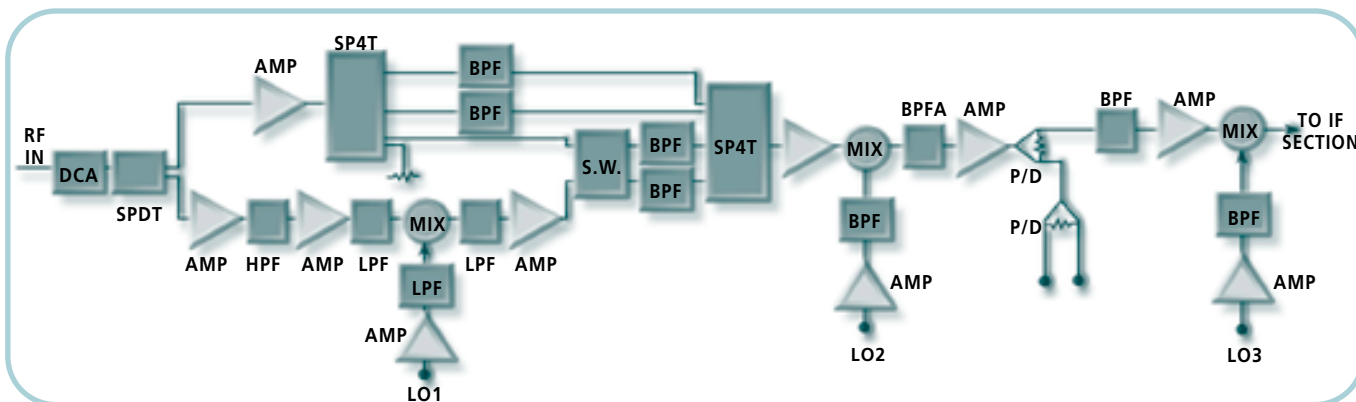
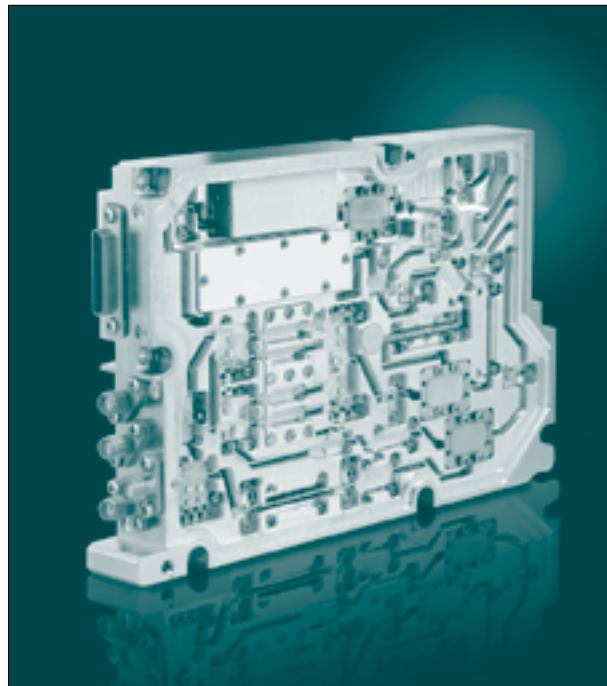

Extended Range DLVA Assy

FREQUENCY RANGE: 1-18 GHz

- ▶ TSS (20 MHz Video BW): -67 dBm
- ▶ Logging Range: -64 to 0 dBm
- ▶ Log Slop: 70mV typ.
- ▶ Log Linearity: (-64 to 0 dBm) ± 2 dB
- ▶ Log Accuracy: ± 3 dB
- ▶ DC Offset: ± 100 mV
- ▶ Matching Between Units: ± 3 dB
- ▶ Frequency Flatness: $\pm 0.5 \pm 1.5$ dB

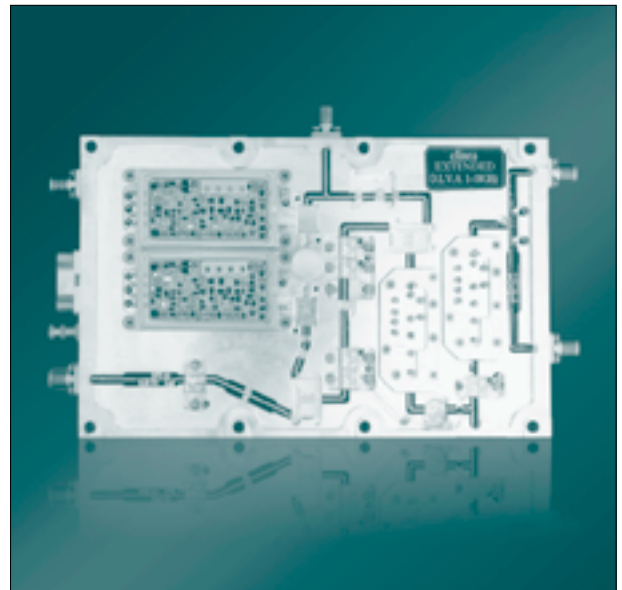

APPLICATION

- ▶ EW Systems

TECHNOLOGY

- ▶ Thin & Thick Film
- ▶ PIN Diode Switches
- ▶ Drop in Hybrid Amplifiers
- ▶ Hermetically Sealed (Laser)

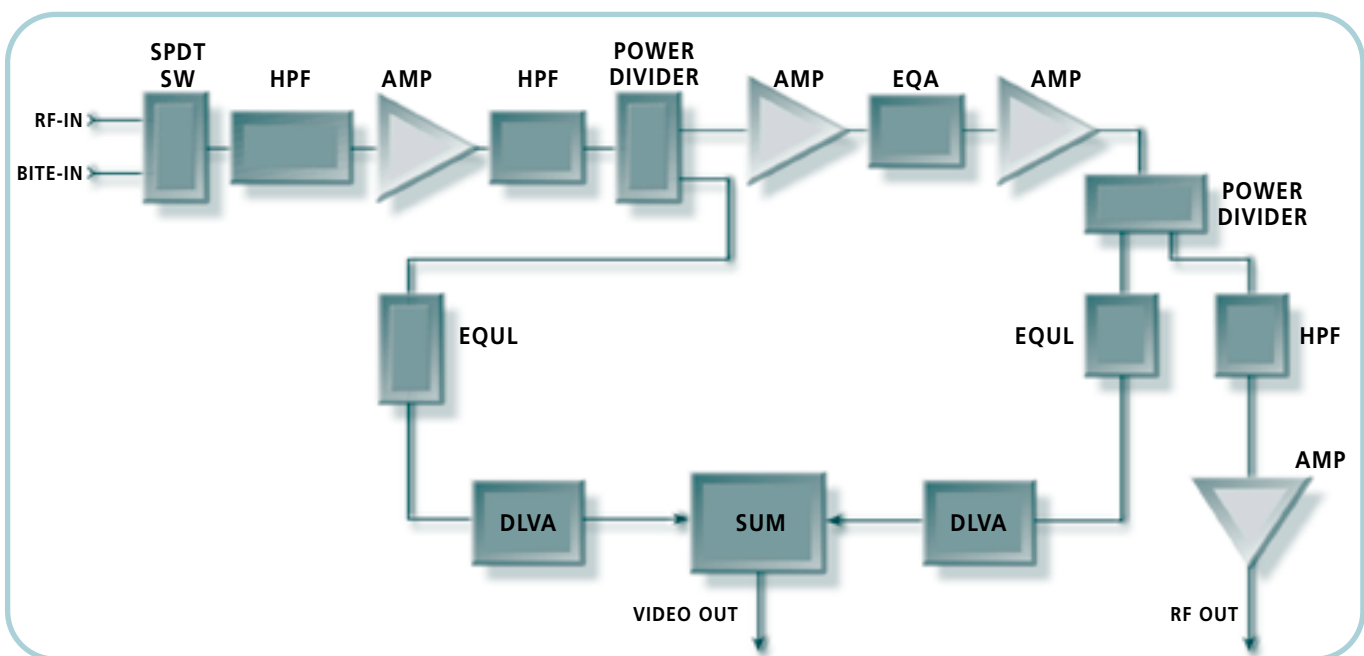

EXTENDED RANGE DLVA ASSY

EXTENDED RANGE DLVA ASSY (continued)

ELECTRICAL SPECIFICATIONS

Frequency Range

1 to 18 GHz

Max. RF Input Power

5W CW

Max. Peak (1 μ s width: 1 kHz PRF)

500W peak

Max. RF Bite Input

0 dBm

TSS (20 MHz Video BW)

-70 dBm

SP2T RF Switch Isolation

60 dB min.

Switching Controls

Logic "O" port "ON"

Switching Time

200 nSec max.

Switch Control Video Leakage

Less than video level corresponding to 66 dBm

RF Output

0 dBm min. at -40dBm input
2nd harmonic level 7 dBc min.

DLVA Type

DC Coupled Extended Dynamic Range

Logging Range

-67 to 0 dBm

Video Output

300 mV @ -65 dBm with SNR of 14 dB

Video Output at 0 dBm

5.7V max.

Log Slope 70 mV typ**Output Response** Monotonic**Log Linearity (-65 to 0 dBm)**

± 1.0 dB Typ.
 ± 1.5 dB @ 87.8%
 ± 1.8 dB max.

Log Accuracy (for set of 10 units)

± 2.5 dB @ 94%
 ± 3.0 dB

DC Offset

± 60 mV

DC Offset Tracking (for set of 10 units)

60m V p-p

Frequency Flatness

± 1.5 dB @30%
 ± 2.0 dB @ 90%
 ± 2.5 dB max.

Pulse Width

50 nsec to 150 μ sec

PRF

50 Hz to 250 kHz

Recovery Time

350 nsec @ 0 dBm
PW = 150 μ sec

Rise Time

20 nsec

Settling Time

35 nsec

IN/OUT VSWR

2:1 @ 85% of band
2.5:1 @ 95% of band
3:1 max.

Filter Response

Filter Pass Band 1 to 18 GHz

Filter Rejection (DC to 850 MHz)
60 dBc

Output Video Load

50 ohm

DC Power Protected for Reverse Polarity Over Voltage up to ± 18 V Short Circuit Protection and EMI/EMC

-15 VDC; 1.3A max.
(1A Typ)

-15 VDC; 300 max.

Connectors

RF Input, Bite, Video
SMA Jack

Supply & Control
D Type

Matching (for set of 10 units)

± 2 @ 80%
 ± 2.5 dB max

Operating Temp. Range

-40 to 85°C

Shock

MIL-STD-202

Vibration

MIL-STD-202

Relative Humidity

95%

Screening

MIL-STD-883B

EMI/EMC

MIL 461C

Mechanical Size

5.5 x 3.5 x 0.6"

Dual Output AGC Unit

FREQUENCY RANGE: 2-6 GHZ

- ▶ Gain @ "0" Att.: 40 dB
- ▶ Attenuation Range: 0-31 dB
- ▶ Switching Speed: 250 nSec

APPLICATION

- ▶ EW Systems

TECHNOLOGY

- ▶ Thin Film
- ▶ Hybrid Balanced Amplifiers
- ▶ PIN Diode Switches
- ▶ Hermetically Sealed (Laser)

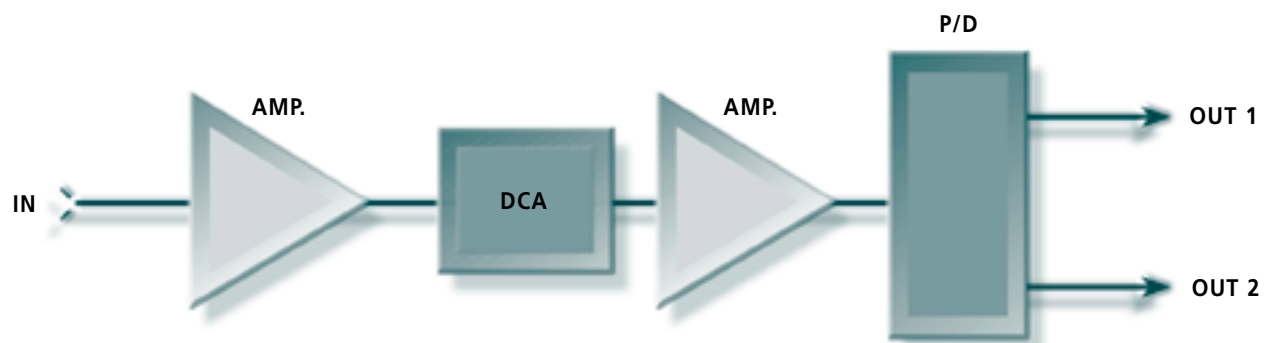
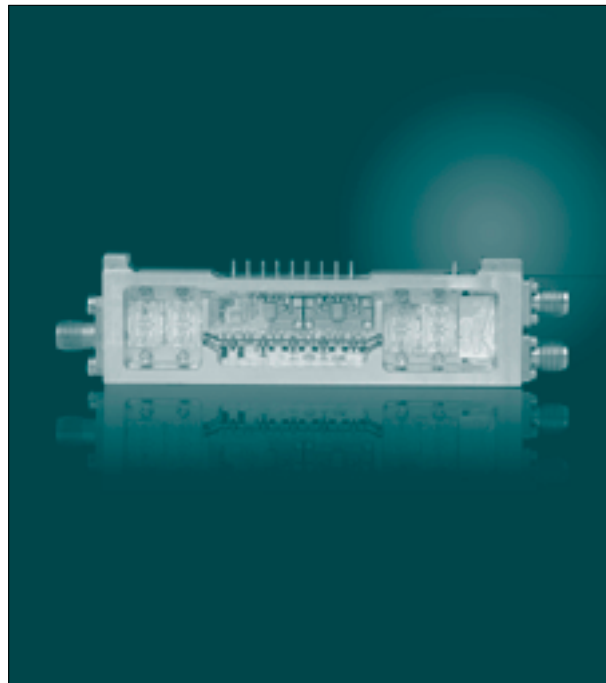

VCO Assy

FREQUENCY RANGE: 2-18 GHz

- ▶ Multi-Channel VCO
- ▶ High Stability
- ▶ Low PTD

APPLICATION

- ▶ EW Systems

TECHNOLOGY

- ▶ MMIC
- ▶ Thin Film
- ▶ Hermetically Sealed (Laser)

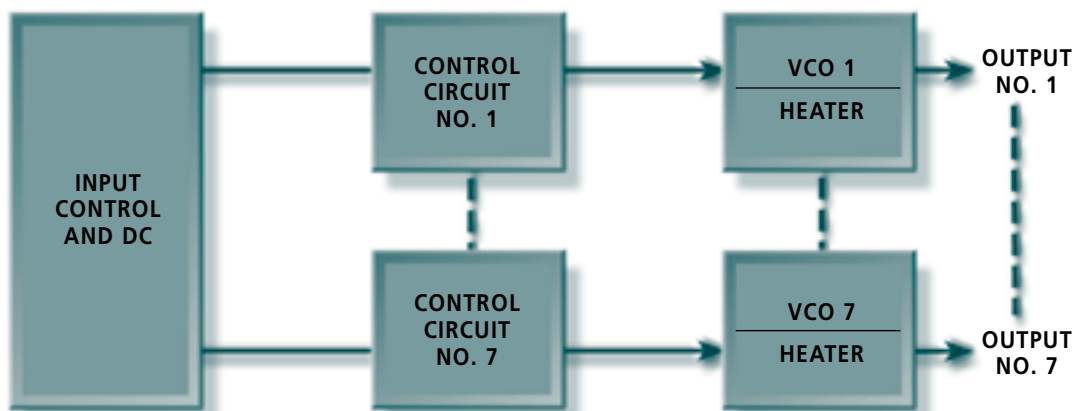
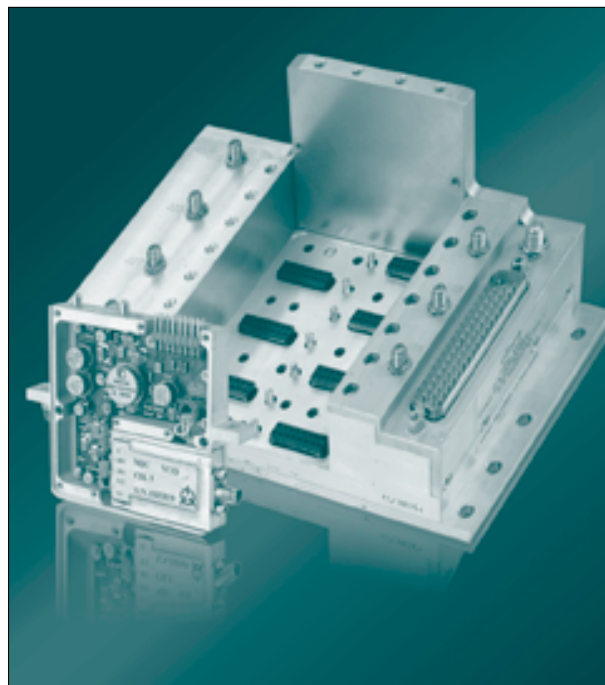

SCOPE

This document describes 7 channels oscillator which consists of control mother-board and 7 oscillator modules. All signals, bias voltages and control signals are supplied via a 50 pin D connector. Modulation signals via coaxial lines.

Each channel gets its own tuning voltage, narrowband modulation (NB) and two control lines which select the mode.

Wideband modulation (WB) is supplied only once for all channels.

Each oscillator can be modulated by its own NB and the common WB modulation signal.

There are two control signals for each channel which switch the desired mode between "OFF", "NB", "WB1" and "WB2".

The modules have to be realized as plug-in devices.

The control mother-board contains all the circuits which distribute and process all control, tune and modulation signals.

ELECTRICAL PERFORMANCE (CARRIER)

Frequency Coverage

- Channel 1: $F1 \pm 100$ MHz
- Channel 2: $F2 \pm 100$ MHz
- Channel 3: $F3 \pm 100$ MHz
- Channel 4: $F4 \pm 100$ MHz
- Channel 5: $F5 \pm 100$ MHz
- Channel 6: $F6 \pm 100$ MHz
- Channel 7: $F7 \pm 100$ MHz

Output Power

Each channel:

- Minimum power vs freq. +10 dBm
- Maximum power vs freq. +20 dBm
- Power variation over whole channel ≤ 2 dB
Ch6: ≤ 2 dB for (HBC_{min}.-100 MHz)...(HBC_{max}.-1 GHz)
Ch6: ≤ 3 dB for full band
- Power variation
Within any 680 MHz ≤ 1 dB
Ch6: ≤ 2 dB for (HBC_{max}.-1 GHz)...HBC_{max}.
- Power variation over temperature ≤ 1 dB

VSWR

Output, 50 ohms $\leq 1.5 : 1$

Frequency Pulling

Frequency change: load VSWR varies over 360 electr. Degrees ≤ 4 MHz

Frequency Pushing

Frequency change: change of bias voltage in spec. limits ≤ 50 MHz/V

Harmonics and Subharmonics

Power of harmonics above freq. band ≤ -20 dBc
Power of subharm. below freq. band ≤ -20 dBc

Spurious

Power of spurious in operation band (includes all harm, and subh. In band) ≤ -50 dB

Warm Up Time

-54°C to +95°C ≤ 3 minutes

Carrier Drift

Carrier drift across whole temp. range $\leq \pm 4$ MHz

Noise Levels

Max. noise floor at ≥ 10 MHz distance from carrier ≤ -60 dBc/MHz
Max. residual FM noise (IF-Bw: 1 kHz, 3 dBc) ≤ 150 kHz

Switching

Any switching in other channels shall not cause changes in the spectrum of the channel monitored after 5 μ s.



Cross Talk

Change of NB_{min} . if WB modulation is applied (any potentiometer setting) $\leq \pm 1$ MHz

Electrical Performance (Modulation):

Mode Selection

Modulation	Control Line1	Control Line2	RF Status
Undef	High	High	RF off
NB	Low	High	RF on
WB1	High	Low	RF on
WB2	Low	Low	RF on

State high: TTL-High: +2.7 +4.5V

State low: TTL-Low: +0.0 +0.8V

Internal pull-up resistor to Vcc is required for all control lines

Switching speed between any mode: 0.1 msec

RF Off Mode

The power of the RF off Mode shall be 80 dB down the RF on mode.

NB Mode

Input modulation for the NB mode is supplied separately for each channel.

Modulation signal characteristics:

Amplitude into load of 90.....100 ohm, AC coupled

Shunted by not less than 300 Ohm reactance: 0.0.....2V..

Frequency components from 0.0520 MHz

Modulation sensitivity variation (MHz/V) $\leq 1.5 : 1$

Bandwidth of modulated RF-Signal:

RF-BW with NB-mod. Input voltage 0.2Vpp $\rightarrow \leq NB_{min}$.

RF-BW with NB-mod. Input voltage 2.0Vpp $\rightarrow \geq NB_{max}$.

Bandwidth change over any 680 MHz $\leq 20\%$

Bandwidth change over full temp. range $\leq \pm 2\%$ or $\leq \pm 5$ MHz

Whichever is less

WB Mode

Input modulation for the WB mode is supplied only once for all 7 channels.

Two independently adjustable RF-bandwidths WB1 and WB2 (2 potentiometers) for each channel

Modulation signal characteristics:

Amplitude into load of 90.....110 Ohm, AC coupled shunted by not less than 300 Ohm reactance 0.0.....2 Vpp

Frequency components from 0.05...30 MHz

Modulation sensitivity variation (MHz/V) $\leq 1.5 : 1$

Bandwidth of modulated RF-Signal:

RF-BW dependent on potentiometersetting $\leq WB_{min}$ $\geq WB_{max}$

Bandwidth change over any 680 MHz $\leq 20\%$

Bandwidth change over full temp. range $\leq \pm 2\%$ or $\leq \pm 35$ MHz

Whichever is less

Accuracy for adj. Potentiometers $\leq \pm 2$ MHz

TUNING CHARACTERISTICS

Tuning Voltage

Tuning voltage for each oscillator is supplied by a pair of twisted wires separately for each channel.

Tuning voltage characteristics

Sawtooth, sinus or square wave 0....300 kHz incl. Const. DC levels

A differential input for a good common mode rejection with a bandwidth of 300 kHz and a load impedance of ≥ 300 pF, is required.

Tuning voltage range -9...+4V

To obtain the whole frequency coverage for each channel a change of tuning voltage of minimum 8V is required.

Frequency must increase with increasing tuning voltage.



NOTE: There is a tested tuning input filter for this version

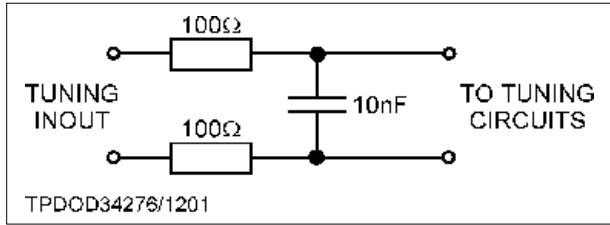

DC Power

+12V± 1V	: 1.8 A max.
-12V±1V	: 1.4 A max
+15V±1V	: 0.5 A max
-15V±1V	: 0.5 A max
+5V±1V	: 0.5 A max

Tuning Linearity

Ratio of max. to min. slop (frequency vs tuning volt.)

For any whole channel
: ≤ 1.5:1

For any 680 MHz portion
: ≤ 1.2:1

Channel 6:

For the whole channel
: ≤ 1.8:1

For any 680 MHz portion
: ≤ 1.2:1

Frequency Setting Repeatability

Accuracy under identical conditions (measured 1 sec. after tuning voltage change earliest) : ≤ ± 2 MHz

Frequency Setting Time (Post Tuning Drift)

Frequency deviation after 0.1 ms
: ≤ ± 10.0 MHz

Frequency deviation after 1.0 ms
: ≤ ± 5.0 MHz

Frequency deviation after 100 ms
: ≤ ± 1.0 MHz

All deviations are related to the frequency after 1 sec. which is assumed to be constant.

Dual Channel Front End Receiver

FREQUENCY RANGE: 0.5÷18, 1÷18, 2÷18 GHz

- ▶ High Output 1 dB Compression: +18 dBm
- ▶ Low Noise Figure: 10 dB
- ▶ Integrated Test Generator
- ▶ B.I.T Capabilities: TTL Compatible
- ▶ Low Power Consumption: 10 Watts

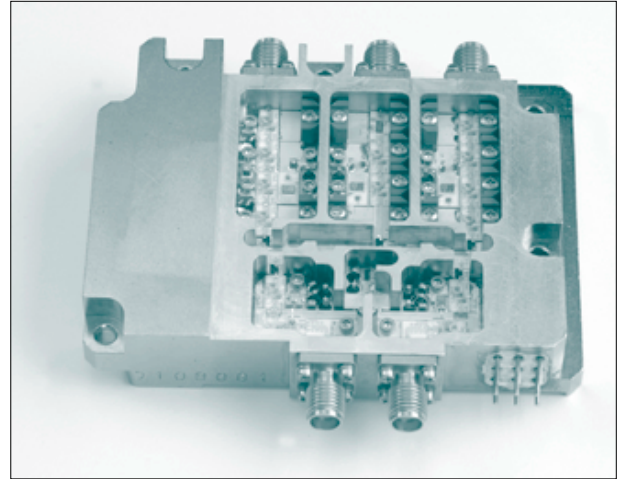

APPLICATION

- ▶ EW-Front End Receivers

TECHNOLOGY

- ▶ Microstrip MIC
- ▶ MMIC Switches
- ▶ Comb Generator
- ▶ SMD
- ▶ Hermetically Laser Sealing

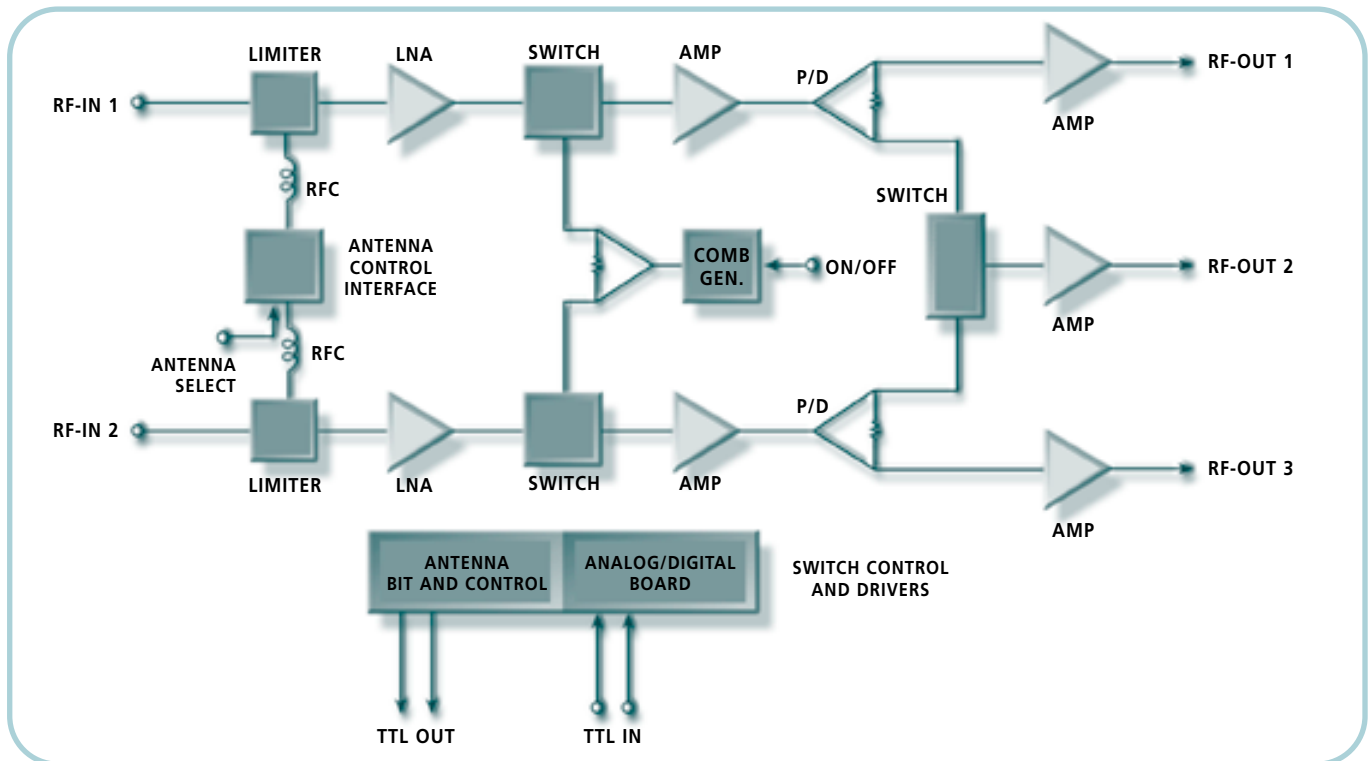

Dual Output Front End Receiver

FREQUENCY RANGE: 2÷18 GHz

- ▶ Low Noise Figure: 10 dB
- ▶ High Output 1 dB Compression: +18 dBm
- ▶ High Path Isolation: 60 dB
- ▶ Low Power Consumption: 9W
- ▶ Low Spurious Level
- ▶ Internal Noise Source For BIT

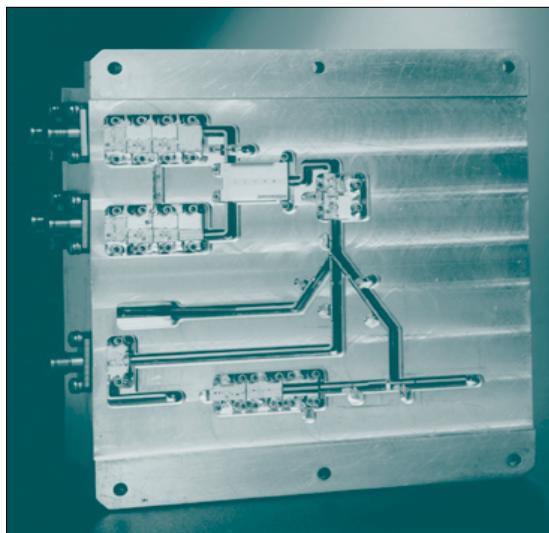

APPLICATION

- ▶ EW-Front End Receivers

TECHNOLOGY

- ▶ Microstrip, Strip Line
- ▶ Comb Generator
- ▶ SMD
- ▶ MIC, MMIC
- ▶ Hermetically Laser Sealing

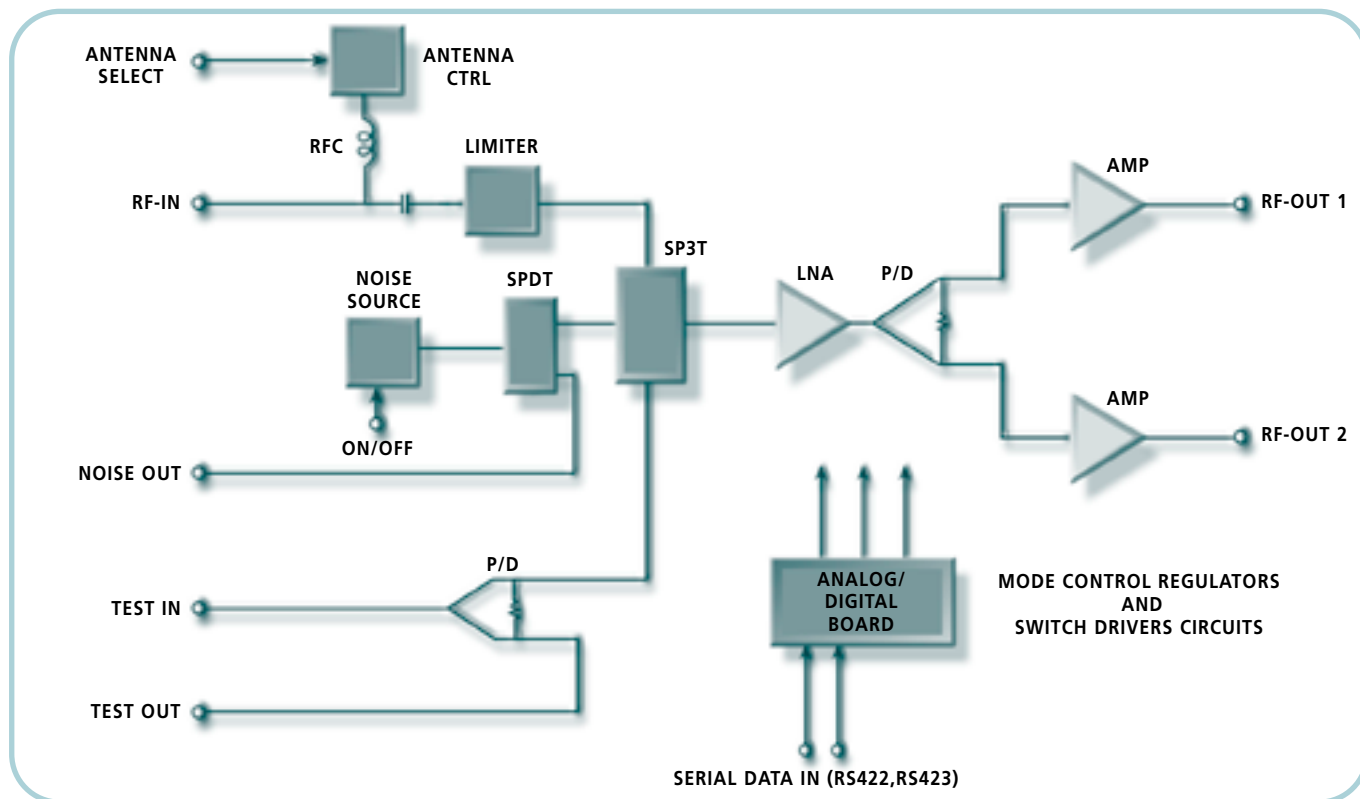

FRONT END RECEIVERS

Dual Band LO Distributor

FREQUENCY RANGE: DUAL BANDS

- ▶ X: 8÷9 GHz
- ▶ UHF: 870 MHz
- ▶ Splitting & Amplifying
- ▶ Detects Input/Output Power Level: TTL Compatible
- ▶ Excellent In/Out VSWR: 1.3:1
- ▶ Excellent Output Stability: Less than ± 1 dBm
- ▶ High Channel Isolation: 60 dB min
- ▶ Low Output Spurious Level
- ▶ Over All Power Consumption: 12W

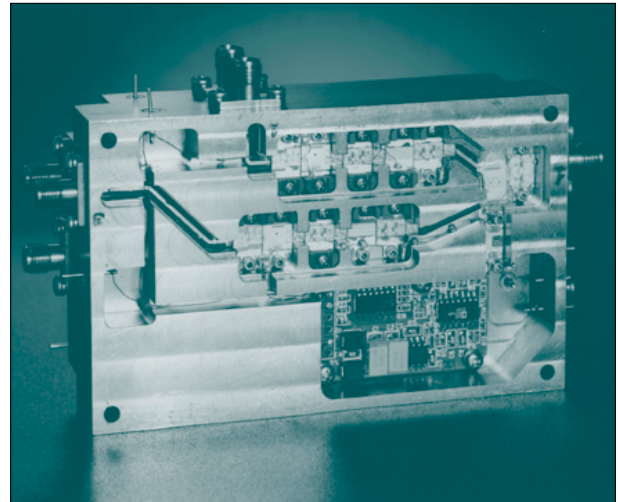

APPLICATIONS

- ▶ EW Systems
- ▶ Transponders
- ▶ Rx/Tx Assemblies

TECHNOLOGY

- ▶ Couplanar Wave Guide
- ▶ MIC For X-Band
- ▶ SMD, MMIC For UHF Channel

